



US010641518B2

(12) **United States Patent**  
**Kennedy**

(10) **Patent No.:** **US 10,641,518 B2**

(45) **Date of Patent:** **May 5, 2020**

(54) **FLOOR VENT ASSEMBLY**

(56) **References Cited**

(71) Applicant: **Joseph Kennedy**, Holly, MI (US)

U.S. PATENT DOCUMENTS

(72) Inventor: **Joseph Kennedy**, Holly, MI (US)

2,786,407 A \* 3/1957 Sarles ..... F24F 13/075  
454/316

(73) Assignee: **Perfect Vents, Inc.**, Holly, MI (US)

3,564,770 A \* 2/1971 Korbelic ..... E06B 7/02  
49/38

(\* ) Notice: Subject to any disclaimer, the term of this patent is extended or adjusted under 35 U.S.C. 154(b) by 296 days.

6,234,894 B1 5/2001 Goracke  
7,819,730 B2 10/2010 Ascroll  
9,777,475 B1 10/2017 Yasinskiy

(21) Appl. No.: **15/833,067**

2003/0220070 A1\* 11/2003 Orendorff ..... F24F 13/082  
454/324

(22) Filed: **Dec. 6, 2017**

2013/0072104 A1\* 3/2013 Picco ..... F24F 13/085  
454/289

(65) **Prior Publication Data**

US 2019/0170390 A1 Jun. 6, 2019

\* cited by examiner

*Primary Examiner* — Steven B McAllister

*Assistant Examiner* — Allen R Schult

(74) *Attorney, Agent, or Firm* — Reising Ethington P.C.

(51) **Int. Cl.**

**F24F 13/068** (2006.01)

**B23P 19/04** (2006.01)

**F24F 13/08** (2006.01)

(57) **ABSTRACT**

A vent cover assembly is disclosed, such as for a floating or fixed floor. Example vent cover assemblies may include a support plate configured to be secured over a duct, and a flush mount vent cover. The support plate may define a plurality of first airflow apertures configured to permit airflow from the duct through the support plate. The vent cover may define a second plurality of airflow apertures that are positioned in the vent cover such that the second plurality of airflow apertures are aligned with the first airflow apertures when the vent cover is in a first installed position overlying the support plate. The vent cover may obstruct the first airflow apertures when the vent cover is in a second installed position overlying the support plate.

(52) **U.S. Cl.**

CPC ..... **F24F 13/068** (2013.01); **B23P 19/04** (2013.01); **F24F 13/084** (2013.01); **F24F 2221/40** (2013.01)

(58) **Field of Classification Search**

CPC ..... F24F 13/068; F24F 13/084; B23P 19/04

USPC ..... 454/289

See application file for complete search history.

**26 Claims, 7 Drawing Sheets**

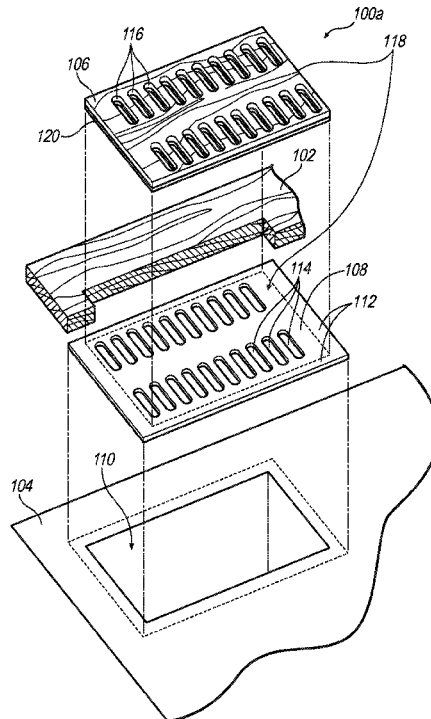

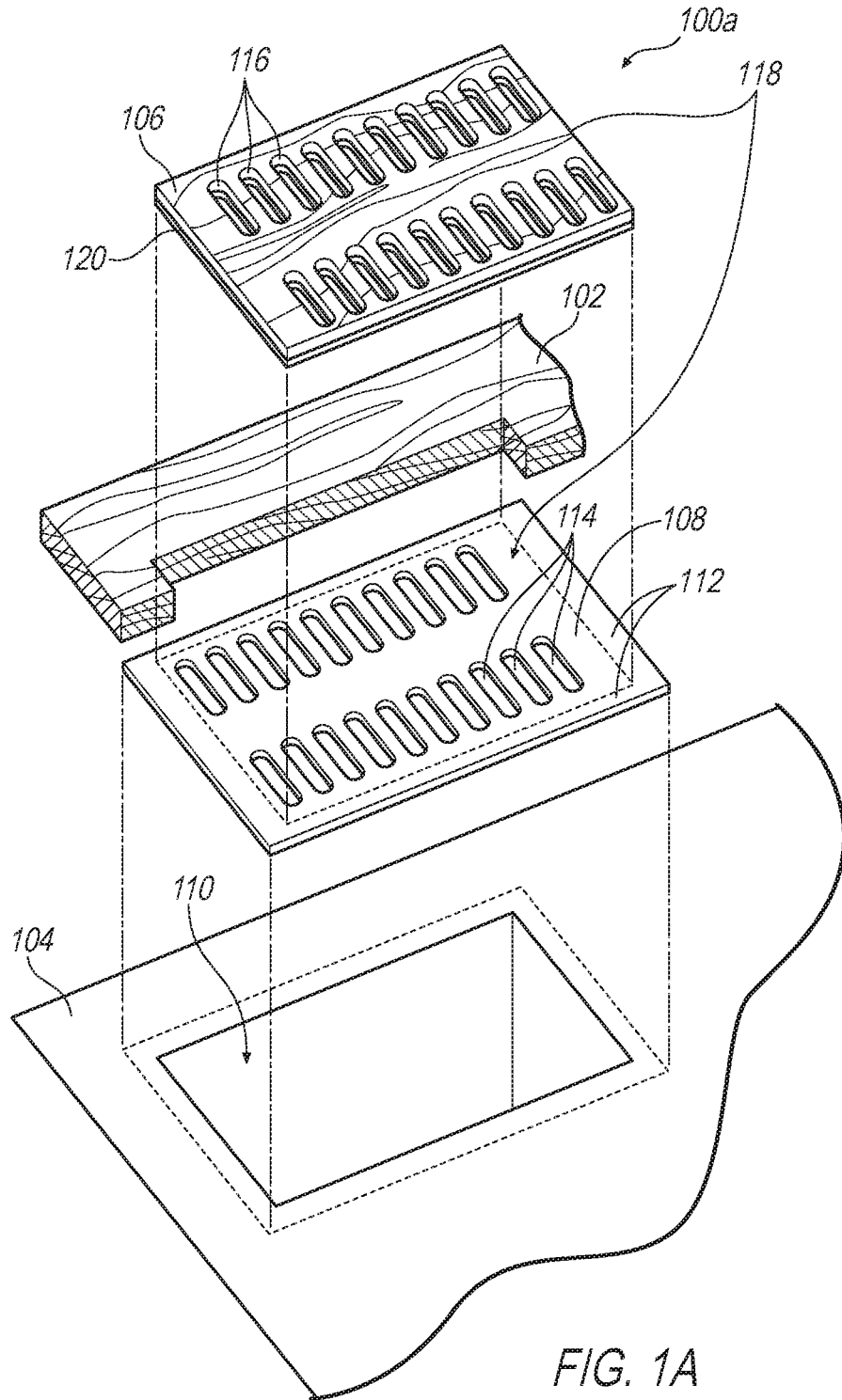

FIG. 1A

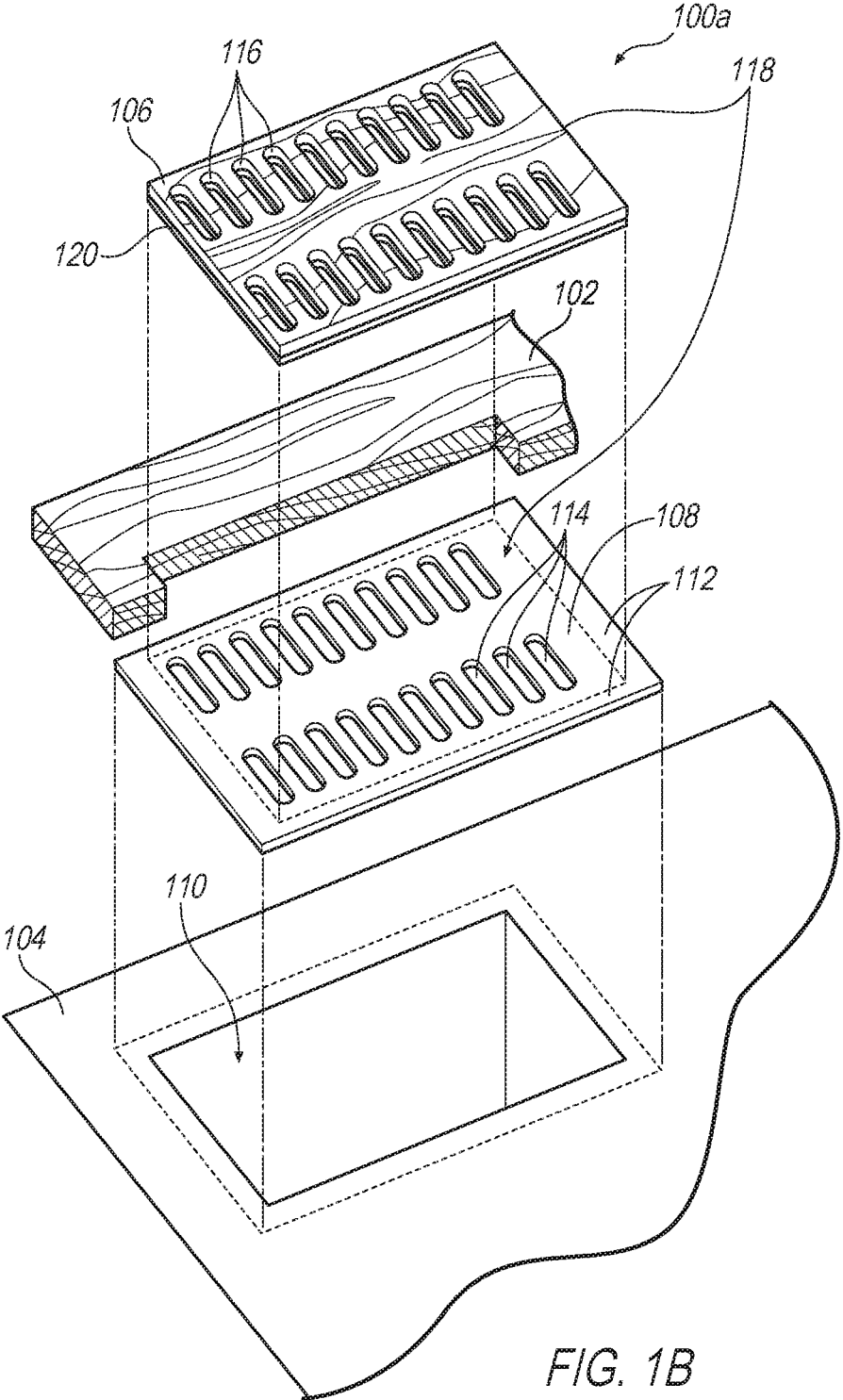

FIG. 1B

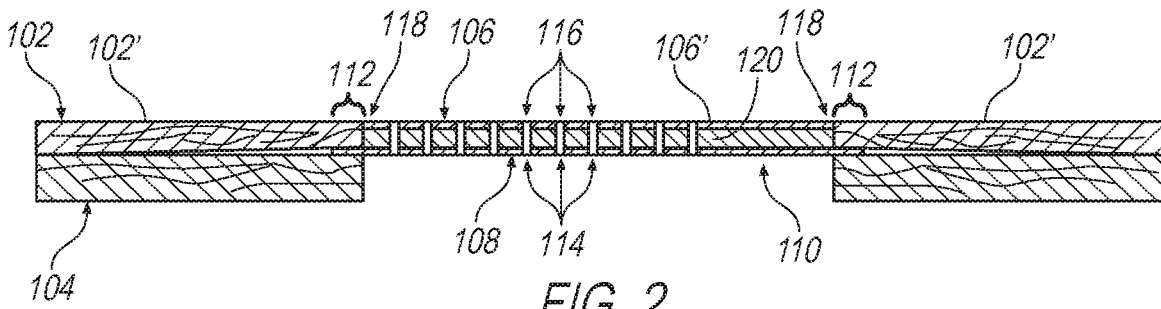

FIG. 2

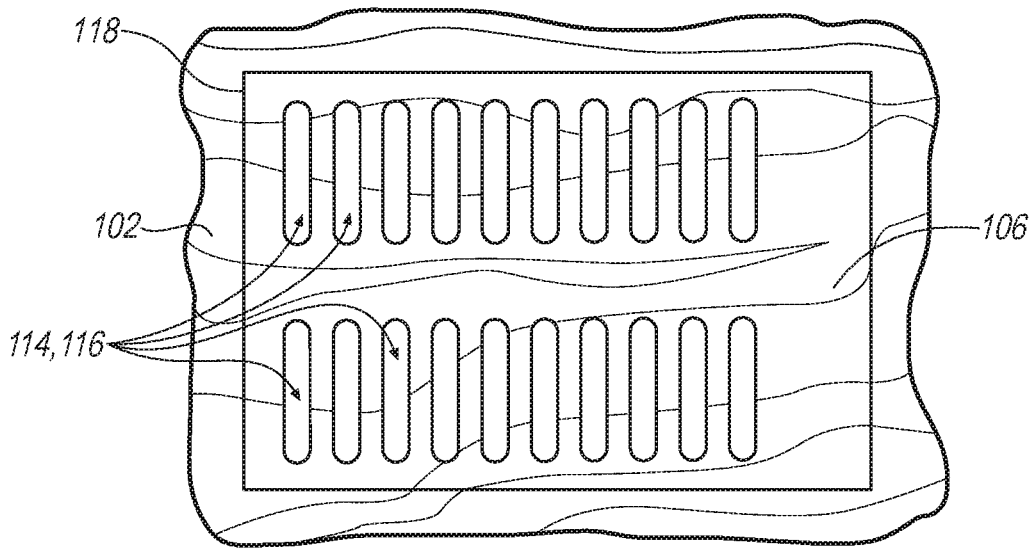

FIG. 3A

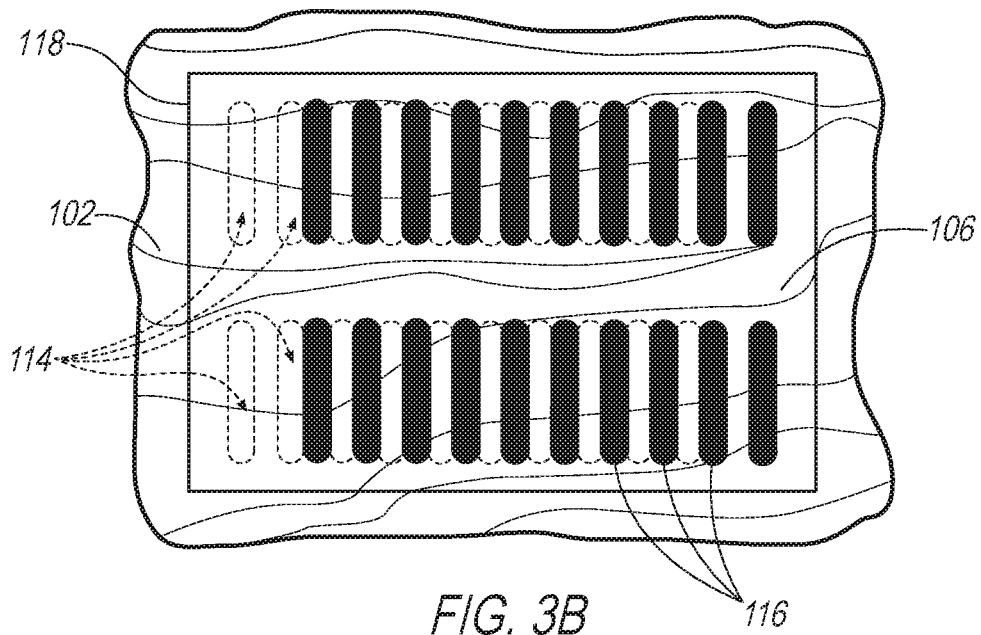

FIG. 3B

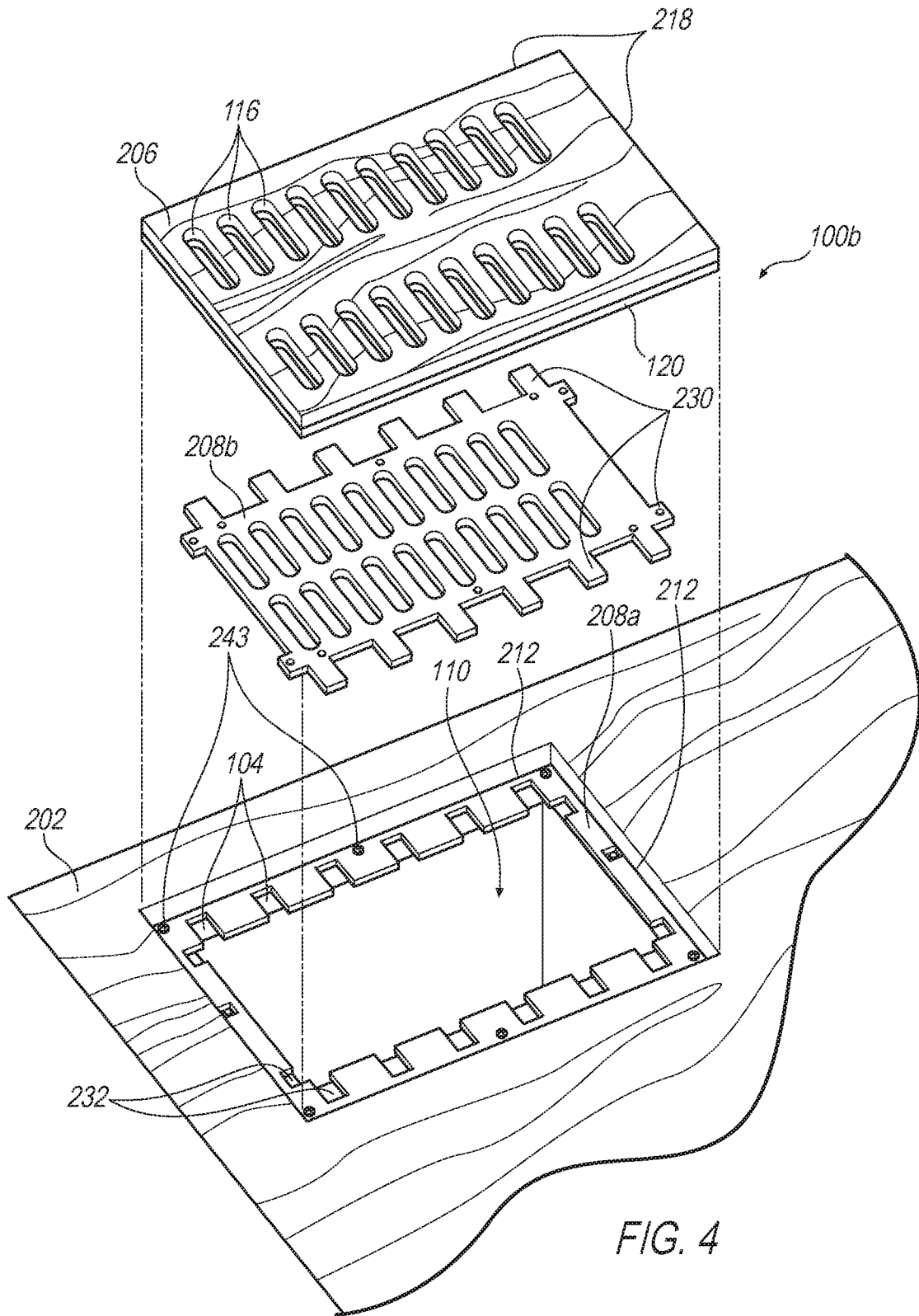
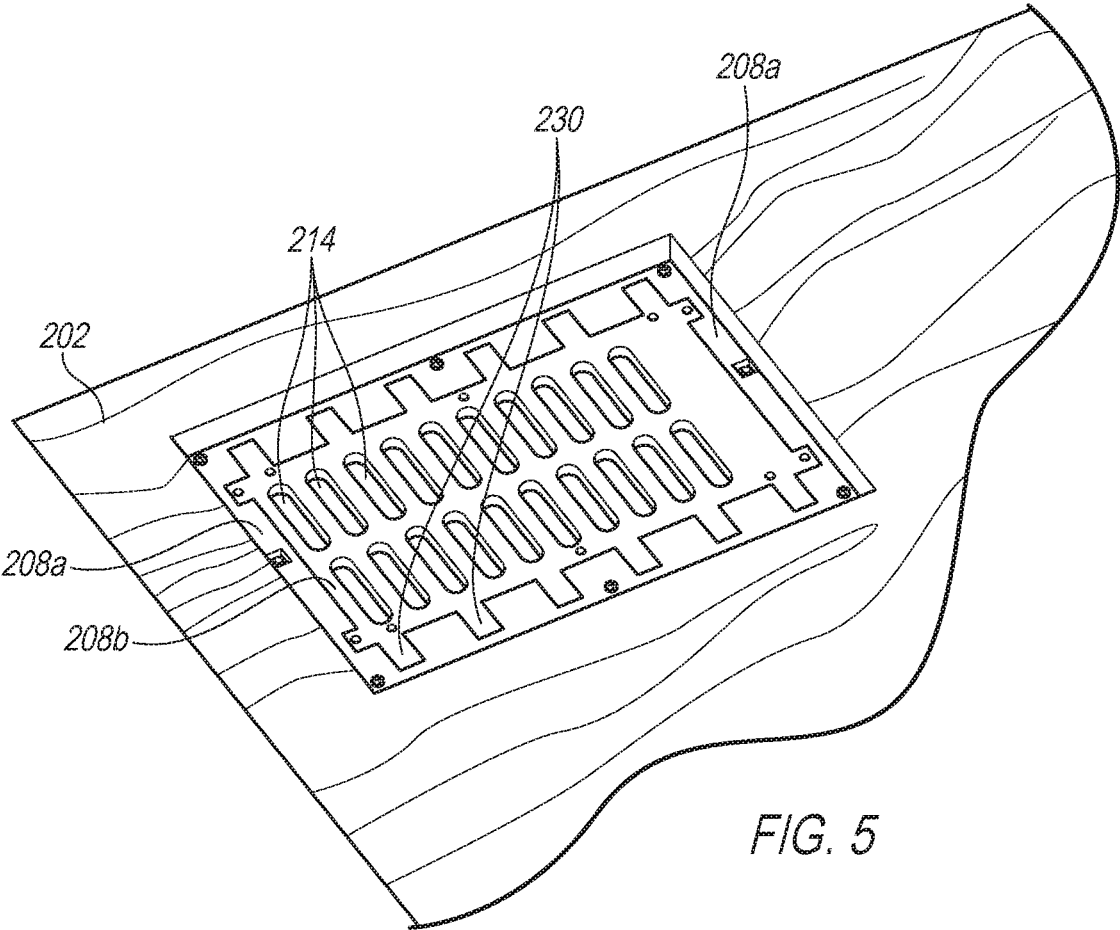

FIG. 4



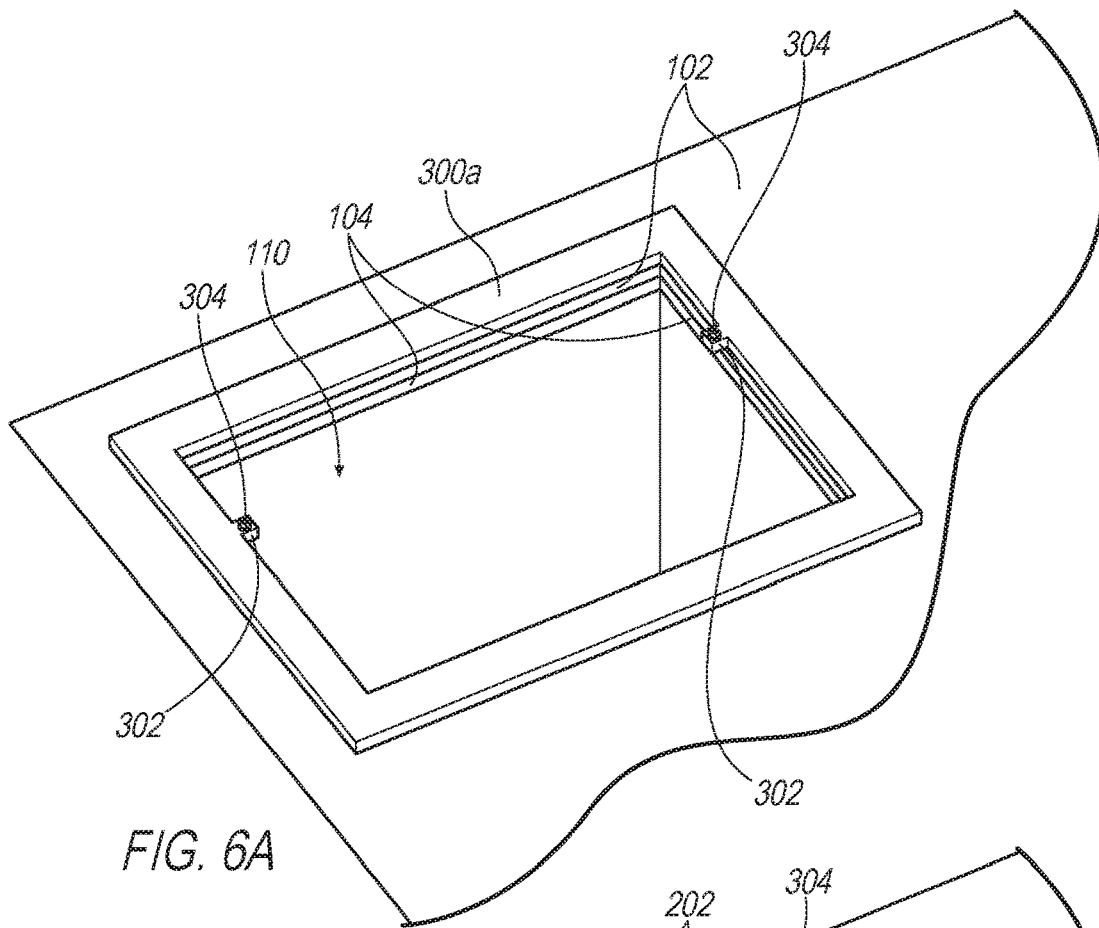

FIG. 6A

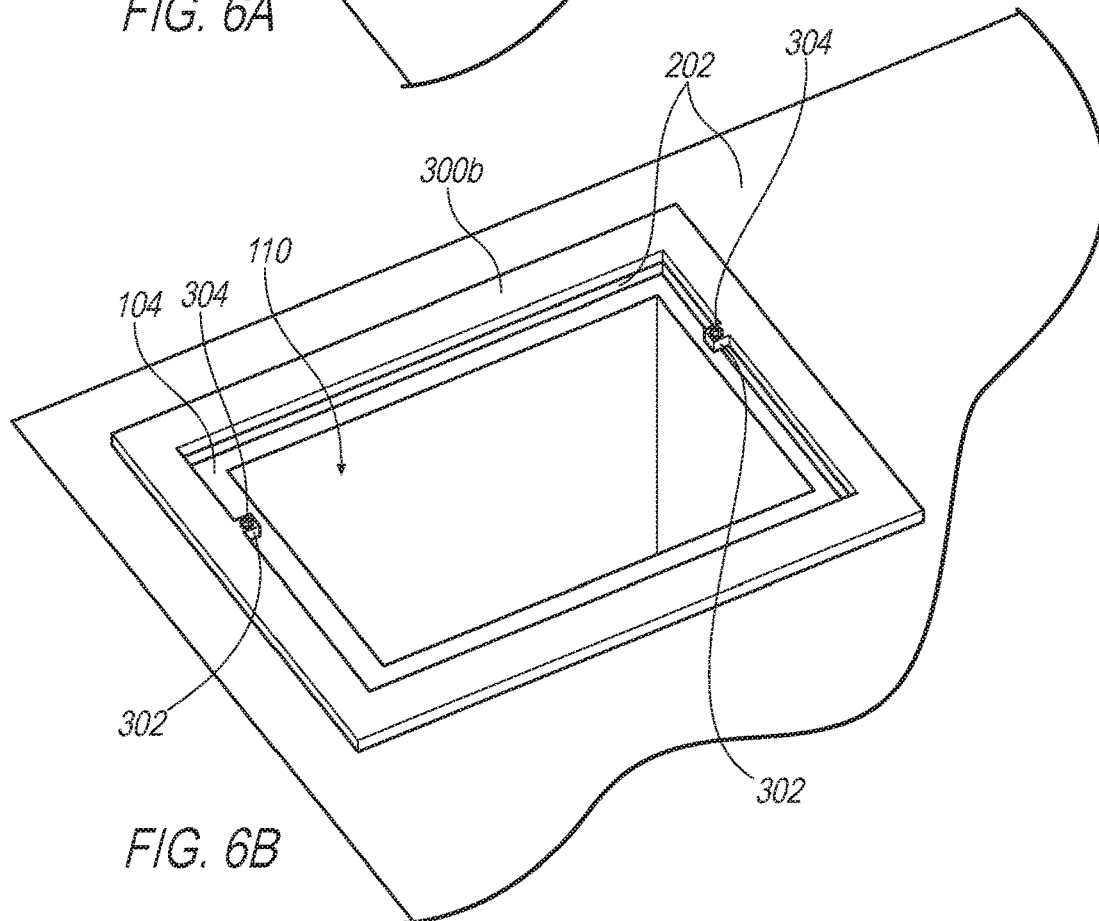

FIG. 6B

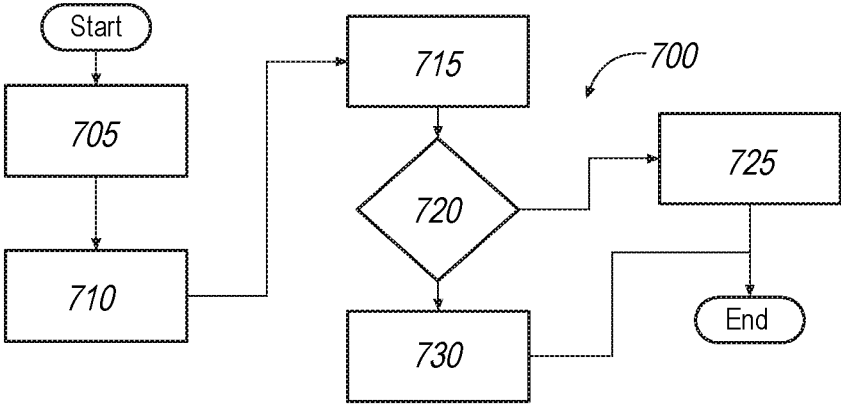

FIG. 7

1

**FLOOR VENT ASSEMBLY**

## BACKGROUND

Floor vents generally allow for the passage of air from heating/ventilation/air conditioning (HVAC) systems into a room. Floor vents typically have covers that are installed such that they protrude above the surrounding floor surface. In addition to their general lack of aesthetic appeal resulting from the discontinuity in floor surface and/or materials, the protrusion of conventional floor vent covers can create a tripping hazard or interfere with the placement of furniture. While some vents have been developed more recently that have a lower profile, they typically employ fixed openings that do not allow for adjustment of a flow rate of air through the vent or for the vent to be closed.

Accordingly, there is a need for an improved floor vent that addressed the above shortcomings.

## BRIEF DESCRIPTION OF THE DRAWINGS

Referring now to the drawings, exemplary illustrations are shown in detail. Although the drawings represent some examples, the drawings are not necessarily to scale and certain features may be exaggerated, removed, or partially sectioned to better illustrate and explain the present invention. Further, the exemplary illustrations set forth herein are not intended to be exhaustive or otherwise limit or restrict the claims to the precise forms and configurations shown in the drawings and disclosed in the following detailed description:

FIG. 1A is an exploded perspective view of a floor vent assembly with a vent cover in an open orientation, according to one example;

FIG. 1B is an exploded perspective view of the floor vent assembly of FIG. 1A with the vent cover in a closed or obstructed orientation, according to an example approach;

FIG. 2 is a section view of the floor vent assembly of FIGS. 1A and 1B, with the vent cover installed in an open orientation, according to one example;

FIG. 3A is a top view of the vent cover assembly of FIGS. 1A, 1B, and 2 with the vent cover installed in an open orientation, according to an example approach;

FIG. 3B is a top view of the vent cover assembly of FIGS. 1A, 1B, 2, and 3A with the vent cover installed in a closed or obstructed orientation, according to one example approach;

FIG. 4 is an exploded perspective view of another vent cover assembly having a support frame secured to a subfloor, according to one example illustration;

FIG. 5 is a perspective view of the vent cover assembly of FIG. 5, with a support plate installed within the support frame, according to one example illustration;

FIG. 6A is a perspective view of a template for establishing a vent aperture in a floor and/or subfloor, according to one example;

FIG. 6B is a perspective view of a template for establishing a vent aperture in a floor and/or subfloor, according to an exemplary approach; and

FIG. 7 is a process flow diagram for an example method of providing a floor vent assembly.

## DETAILED DESCRIPTION

Exemplary illustrations are disclosed below in regard to a vent cover assembly and associated methods, such as for installing a vent cover assembly. Generally, a vent cover

2

assembly may be installed flush with the surrounding area, i.e., the surrounding floor surface, such that it does not protrude outward from the surface of the flooring, or noticeably so. Moreover, there is generally no restriction on what materials the vent cover can be formed of. In some examples, the vent cover is formed from the same material as the flooring, so as to blend in with the flooring. While the various examples herein are directed to floor vents located within floors, example illustrations may also be adapted for use in other surfaces, e.g., wall surfaces or ceilings.

Example vent cover assemblies may also permit opening and closing of the vent, thereby permitting selective adjustment to a flow of heated/cooled air into a room. In at least some examples, a floor vent assembly includes a support plate and a vent cover that each define respective airflow openings. More specifically, the support plate may be configured to be secured over a duct, and define a plurality of first airflow apertures through which air may flow from the duct. A flush mount vent cover may have an upper surface configured to extend substantially continuous with an adjacent floor surface when installed overlying the support plate, thereby providing a substantially flush floor surface. The vent cover defines a second plurality of airflow apertures that are positioned in the vent cover such that they are aligned with the first airflow apertures when the vent cover is in a first installed position overlying the support plate, thereby allowing air to flow from the duct and into the room. In a second installed position overlying the support plate, the vent cover obstructs the first airflow apertures, thereby restricting or cutting off entirely the flow of air from the duct into the room. The vent cover may be selectively repositioned between the first and second installed positions, thereby allowing selective opening/closing of the vent cover assembly.

In some examples, a vent cover assembly may be used in connection with a floating floor, i.e., a floor that is laid over a subfloor without being nailed, glued, bonded, or otherwise permanently affixed directly to the subfloor. In such floating floor installations, the support plate may generally be enlarged with respect to an opening in the floor surface through which a heating/ventilation/air conditioning (HVAC) duct forces air. For example, an outer perimeter of the support plate may be sandwiched between an underside of the flooring and the subfloor (which is disposed beneath the flooring). The vent cover may be relatively smaller than the support plate in these cases, fitting into an opening defined by the floor surface.

In other examples, a vent cover assembly may be installed into a fixed flooring system, i.e., where the flooring is secured to a subfloor by way of nails, glue, bonding, or the like. In these examples, an outer frame may be provided which at least partially surrounds the support plate. The outer frame may be secured to a subfloor, within an aperture in the flooring provided for an HVAC duct. The outer frame, by being secured to the subfloor, generally maintains a fixed space for the support plate in the flooring system, and permits the support plate to be selectively removeable from the outer frame.

As generally noted above, example vent covers may include openings or apertures that are selectively aligned with corresponding openings or apertures in the support plate, thereby permitting opening/closing of the vent assembly. In some examples, the openings of the vent cover may be asymmetrically aligned with an outer perimeter of the vent cover. The vent cover may be installed overlying the support plate in two distinct positions relative to the support plate. More specifically, in a first position, the openings of

the vent cover will generally line up with the openings of the support plate, thereby freely allowing the passage of air from the duct to pass through the vent cover assembly. The vent cover may then be lifted out of the assembly, rotated 180 degrees, and reinstalled overlying the support plate in a second position. In the second position, the openings of the vent cover are shifted laterally with respect to those of the support plate as a result of the asymmetric arrangement of the apertures in the vent cover. Accordingly, airflow through the vent cover assembly from the duct is inhibited or blocked entirely.

Turning now to FIGS. 1A, 1B, and 2, an example vent cover assembly 100a is illustrated and described in further detail in connection with a floating floor. More specifically, a floating floor 102 is generally overlaid upon a subfloor 104 (FIGS. 1A and 1B are vertically exploded views, and thus floor 102 is shown spaced vertically away from the subfloor 104 in those examples). The floating floor 102, however, is not directly secured to the subfloor 104, e.g., by nails or other mechanical fasteners, glue, or the like, and thus is decoupled from the subfloor 104 (hence the "floating" nomenclature). Moreover, while the floating floor 102 is generally stationary upon the subfloor 104, the floating floor 102 may be spaced from associated walls of the room (not shown) by a relatively small space or gap to permit expansion/contraction of the floating floor 102, allow for manufacturing tolerances, etc.

The vent cover assembly 100a may include a support plate 108 and a vent cover 106. The vent cover assembly 100a may be installed over an HVAC duct opening 110 in the floating floor 102, which conducts heated or cooled air into a room associated with the floor 102 and subfloor 104. It should be understood that the disclosed assembly can be used with any number of different flooring systems and is not specifically limited to the floating floor system of FIGS. 1A, 1B, and 2.

The floor 102 may be formed of any flooring material that is convenient, such as laminate, engineered wood, solid wood, vinyl, cork, bamboo or any alternative material suitable for flooring. Furthermore, as will be described further below, the floor vent assembly 100a can be installed generally at the same time the floor 102 is installed (e.g., in a new construction application) or after the floor 102 is installed (i.e., as a replacement for an existing floor vent). While the flooring 102 is cut away in FIGS. 1A and 1B to better illustrate the structure of the vent assembly 100a, it may extend substantially over an entire subfloor 104, and may generally surround the vent cover 106. Flooring 102 in one example can be a rectangular piece of laminate wood flooring as illustrated, but it should be appreciated that flooring of any shape or configuration can also be used.

In the example illustrated in FIGS. 1A, 1B, and 2, an outermost perimeter 112 of the support plate 108 is sandwiched between the subfloor 104 and floor 102, and the main portion of the support plate 108 sits atop the opening to the vent. The vent cover 106 rests directly upon the support plate 108, and is of such a thickness as to allow it to lay flush with the surrounding floor. For example, as best seen in FIG. 2, an upper surface 106' of the vent cover 106 is generally parallel to and substantially continuous with a flooring upper surface 102'. Both the support plate 108 and vent cover 106 define airflow apertures 114 and 116, respectively, to allow for airflow from the vent opening 110 into the.

As best seen in FIGS. 1A, 1B, and 2, the support plate 108 is illustrated in a rectangular shape, however it should be noted that any shape convenient may be used. The support plate 108 may be relatively thinner than the floor 102 and

subfloor 104, allowing it to fit between the subfloor 104 and floor 102 without creating a noticeable or significant difference in floor height around the vent cover assembly 100a. At the same time, the support plate 108 may be strong enough to support any reasonable weight or pressure that ordinary flooring would be expected to withstand. Moreover, the support plate 108 may be formed of any material that is flexible and can withstand the varying temperature of air that is expected to be released by an HVAC system. One example of a suitable material for the support plate is steel. In a further example, the support plate is formed of a 20-gauge stainless steel plate ( $\frac{1}{32}$  inches thick). This thickness is also within generally accepted height variations for flooring. In other words, while the support plate 108 may cause a small relative vertical spacing between the subfloor 104 and floor 102 adjacent the vent cover 106 (best seen in FIG. 2), this relatively small spacing may be within generally accepted height variations for flooring systems.

Additionally, while the support plate 108 and the support plate outermost perimeter 112 are illustrated in FIGS. 1A, 1B, and 2 as being formed integrally together, the support plate 108 need not be a monolithic single piece. Merely by way of example, it is possible for the support plate 108 and the support plate outermost perimeter 112 to be made of differing materials. In some applications, for example, the support plate could be steel and the support plate outermost perimeter could be rubber or plastic. In another example, the support plate 108 may be formed of a generally single monolithic sheet steel, with the outer perimeter 112 being coated, e.g., with a rubber or plastic material, to facilitate installation of the support plate 108, inhibit corrosion, or the like.

The support plate 108, as illustrated in the example of FIGS. 1A, 1B, and 2, is generally larger than the vent opening 110, such that the support plate outermost perimeter 112 extends past the perimeter of the vent opening 110 by some distance, thereby supporting the support plate 108. The support plate outermost perimeter 112 should be sufficiently large enough that it will allow for the support plate 108 to be held in place while sandwiched between the floor 102 and subfloor 104, and for the remaining exposed portion of the support plate 108 to receive the vent cover 106.

The vent cover 106 comprises a plurality of vent cover air flow apertures 116 and in one example is able to be removably placed over the support plate 108. More specifically, the vent cover 106 may be overlaid upon the support plate 108, with the vent cover apertures 116 positioned above the corresponding support plate airflow apertures 114. The vent cover air flow apertures 116 span the depth of the vent cover 106, such that they extend from an uppermost surface 106', downward and through the vent cover 106. As illustrated, the support plate airflow apertures 114 and 116 may each be generally elongated or rectangular shaped. However, it should be noted that other shapes and configurations of the openings 114, 116 can be used. For example, instead of having two rows of apertures as illustrated in FIGS. 1A, 1B, and 2, there could be a single row of longer apertures that are longer. Moreover, while the apertures 114 in the support plate 108 are illustrated as having substantially identical size and shape as the apertures 116 of the vent cover 106, this is not required.

The vent cover 106 is of an appropriate size to fit over an exposed portion of the support plate 108 and fill any gaps in the flooring 102 surrounding the vent cover 106. The vent cover 106 has a vent cover outermost perimeter 118 that is generally smaller than the support plate 108 and the support plate outer perimeter 112, as best seen in FIGS. 1A and 1B.

5

As mentioned above, in some examples the vent cover **106** is made out of the same material as the flooring **102** so as to blend in with the flooring and be unobtrusive. Any flooring material such as laminate, engineered wood, solid wood, vinyl, cork, bamboo or any alternative material suitable for flooring may be employed in connection with the vent cover **106** and/or flooring **102**. Merely by way of example, the vent cover **106** and floor **102** are each illustrated as having a matching woodgrain appearance on the upper surfaces **106'**, **102'** thereof, respectively.

As best seen in FIG. 2, the vent cover **106** may be trimmed down on a back side or underside thereof, to accommodate the depth of the vent opening, i.e., from the support plate **108** to the upper surface **102'** of the floor **102**, so that the vent cover **106** lays flush with the surrounding floor **102**. When the support plate **108** is made of steel (or any other magnetically susceptible material), the vent cover **106** may have a magnetic material layer **120** applied to a backside or underside of the vent cover **106**, so as to help with maintaining the installed position of the vent cover **106** upon the support plate **108**. The magnetic material layer **120** may cover a portion of or the entire underside surface of the vent cover **106** (as best seen in FIG. 2). Where the magnetic material layer **120** extends across the entire backside of the vent cover **106**, the magnetic material layer **120** may also be cut with openings aligned to the vent cover airflow apertures **116** of the vent cover **106**.

As mentioned above, in the example illustrated in FIGS. 1A, 1B, and 2, the airflow apertures **116** are defined by the vent cover **106** such that they are positioned asymmetrically lengthwise with respect to the vent cover outermost perimeter **118**. The vent cover assembly **100a** may thereby be opened and closed by simply lifting and rotating the vent cover **106**. More specifically, as shown in FIGS. 1A, 2, and 3A, the vent cover **106** may be placed in a first position overlying the support plate **108**. In the first position, the vent cover apertures **116** are aligned with the support plate apertures **114**, such that airflow from the duct **110** through the vent cover assembly **100a** is freely permitted. The vent cover assembly **100a** may be closed by lifting the vent cover **106** from the support plate **108**, rotating the vent cover **106** by 180 degrees, and replacing upon the support plate **108**. As shown in FIGS. 1B and 3B, in this second position the vent cover apertures **116** are shifted with respect to the support plate apertures **114**, such that the vent cover apertures **116** are no longer aligned vertically with respect to the support plate apertures **114**. As such, the support plate **108** partially or entirely blocks the vent cover apertures **116**, and airflow through the support plate apertures **114** is inhibited or blocked entirely. It should be noted that any degree of asymmetry of the vent cover apertures **116** may be employed that is convenient. In the drawings, particularly in FIGS. 3A and 3B, the asymmetry of the vent cover apertures **116** with respect to the outer perimeter **118** of the vent cover **106** is visually emphasized in order to more effectively illustrate the effect of the asymmetry. In practice, however, the vent cover apertures **116** need only be asymmetric with respect to the symmetrical outer perimeter **118** of the vent cover **106** to a relatively small degree. More specifically, the vent cover apertures **116** need only be asymmetric to a sufficient degree that allows sufficient shifting of the apertures **116** with respect to the support plate apertures **114** when the vent cover **106** is switched between the first and second installed positions overlying the support plate **108**.

The provision of a magnetic material layer **120** on the backside/underside of the vent cover **106** may enhance the degree to which the vent cover **106** blocks airflow through

6

the support plate apertures **114**, by ensuring the vent cover **106** remains positioned in direct contact with the support plate **108** despite a relatively increased air pressure in the duct opening **110** due to the operation of the HVAC system.

While the vent cover apertures **116** are illustrated in FIGS. 1B and 3B as entirely obstructing the support plate apertures **114** in the second/closed position, in other examples the apertures **114**, **116** could be offset such that when rotated the support plate apertures **114** would be only partially blocked by the vent cover **106**, so as to allow some air to enter the room but not as much as when the vent cover assembly **100a** is fully open. Additionally, while the asymmetry of the vent cover apertures **116** is illustrated as being with respect to a length of the vent cover **106**, it is possible to achieve the same results by placing the airflow apertures of the vent cover asymmetrically with respect to the width (i.e., shorter dimension) of the vent cover. Accordingly, any asymmetrical arrangement of the apertures **116** with respect to a symmetric outer perimeter **118** of the vent cover **106** may be employed that is convenient. Moreover, while the symmetrical vent cover outer perimeter **118** of the vent cover **106** is illustrated herein with a generally rectangular shape typical of vent registers, any other shape may be employed that is convenient.

The vent cover assembly **100a** may be installed at the time of installation of the floor **102**, or as a replacement to an existing vent/register in the floor **102**. When installed at the same time as floor **102**, some or all of the material used to form the vent cover **106** may be cut directly from the floor **102**, thereby providing the opening in the floor **102** for the duct **110**. The support plate **108** may be positioned upon the duct **110**, and the floor **102** overlaid upon the subfloor **104**, thereby retaining the support plate **108** against the subfloor **104**. Conveniently, where the installation is being made into a floating floor system, e.g., such as with floor **102**, the location of a hole cut for the vent is not as essential as the dimension of the hole, as the entire floor **102** is decoupled from the subfloor **104** (i.e., "floating") and is not fixed to the subfloor **104**. Examples for providing an appropriate hole in the floor **102** will be discussed further below.

Turning now to FIGS. 4 and 5, another example vent cover assembly **100b** is illustrated. The vent cover assembly **100b** includes a vent cover **206** having vent cover apertures **116** which are selectively aligned with and offset with respect to support plate apertures **114**. Accordingly, repositioning of the vent cover **206** in the first and second positions, and opening/closing of the vent cover assembly **100b** in general is as described above in connection with vent cover assembly **100a**.

The vent cover assembly **100b** includes an outer frame **208a** and support plate **208b**, upon which the vent cover **206** is overlaid. The outer frame **208a** is secured to subfloor **104** by one or more mechanical fasteners **243**, e.g., screws or the like. The floor **202**, in contrast to the floating floor **102** described above, may be a fixed flooring system, i.e., such that the floor **202** is secured to the subfloor **104** with nails, glue, or any other means that is convenient. A hole in the floor **202** may be cut such that the subfloor **104** is partially exposed, allowing the outer frame **208a** to be directly fixed to the subfloor **104**, as best seen in FIG. 4. The outer frame **208a** may partially or entirely surround the support plate **208b**, and generally provide a fixed position for the support plate **208b** with respect to the subfloor **104** and floor **202**. Additionally, while the outer frame **208a** is generally secured to the subfloor **104** with the mechanical fasteners **243**, the support plate **208b** is selectively removable from the outer frame **208a**, thereby permitting removal for access

to the duct opening **110** beneath. The outer frame **208a** defines a plurality of recess openings **232**, which receive corresponding tabs **230** of the support plate **208b**. Moreover, the tabs **230** may rest upon the portion of the subfloor **104** supporting the outer frame **208a**, thereby vertically retaining the support plate **208b** within the outer frame **208a**.

In contrast to the relatively larger support plate **108** (which has an outer perimeter **112** extending beyond the outer perimeter **118** of the vent cover **106**) illustrated in FIGS. **1A**, **1B**, and **2**, the support plate/outer frame assembly **208a/208b** may be relatively smaller. More specifically, as best seen in FIG. **4**, the outer frame **208a** and support plate **208b** together may have a same width and length as the vent cover **206**. A hole cut into the floor **202** may therefore be large enough to receive the outer frame **208a**/support plate **208b**, and the vent cover **206** overlying upon the outer frame **208a**/support plate **208b**.

Conveniently, the fixing of the outer frame **208a** to the subfloor **104** allows the vent cover **206** to be installed some time after initial installation of the floor **202**. In one example, upon installation of the fixed floor **202**, a hole may be cut in the floor **202** corresponding to the location of the duct **110**. Material removed from the floor **202** may, in some cases, be used to form the vent cover **206**. Forming the vent cover **206** from the removed material may require offsite processing, e.g., cutting of the vent cover apertures **116**, thinning of the vent cover **206** to allow addition of magnetic material layer **120**, etc. During the time this offsite processing or manufacturing occurs, the support plate **208b** and outer frame **208a** may remain installed, since the outer frame **208a** is fixed in place with respect to the subfloor **104**, as is the surrounding floor **202**. The fixing of the outer frame **208a** may advantageously allow installation of flush mount vent cover assembly **100b** to be completed some time after the fixed floor **202** is installed (e.g., sufficient to allow offsite processing/manufacturing of the vent cover **206**). As such, it is not required to install the vent cover assembly **100b** at the time of installation of the surrounding fixed floor **202**. The fixed floor **202**, in contrast to a floating floor such as floor **102**, generally must be accurately positioned with respect to the vent **110** (due to the need to generally fix the lateral position of the fixed floor **202** with respect to the subfloor **104**), and the outer frame **208a** may hold that position (and space for the vent cover **206**) properly by being fixed to the subfloor **104**.

Accordingly, in both the floating floor **102** (illustrated in FIGS. **1A**, **1B**, and **2**) and fixed floor **202** (illustrated in FIGS. **4** and **5**) examples, a vent cover assembly **100a**, **100b** may be installed at the time of installation of the floor **102/202**, or as a replacement to an existing vent/register in the floor **102/202**, respectively. In examples where the vent cover assembly **100a**, **100b** is being installed as a replacement for an existing vent or register, or as an entirely new vent, an opening may be cut in floor **102**, **202** in an appropriate location (i.e., corresponding to the position of the duct **110**) using a frame or other template that defines an appropriate size/shape for the opening.

Turning now to FIGS. **6A** and **6B**, examples of a template are illustrated, which may be used to form a hole or aperture in a floor **102**, **202** for installing a flush mount vent cover assembly **100a**, **100b**.

In FIG. **6A**, a frame **300a** is illustrated that may be used to form a hole in the floating floor **102** corresponding to the duct opening **110**. A hole of similar or identical size may be formed in the subfloor **104** using the frame **300a**. The frame **300a** generally defines an interior dimension corresponding to the hole being formed in the floor **102** and subfloor **104**.

The frame **300a** may be secured to the floor **102**, e.g., by way of mechanical fasteners such as self-tapping screws **304** which are received in offset tabs **302**. A saw, grinding tool, cutting tool, or the like may be used to cut away material from the floor **102** within the frame **300**.

The frame **300a** may be provided with an inside hole or dimension fractionally larger than the vent cover **106**, such that the vent cover **106** may be dropped in upon the support plate **108** (not shown in FIG. **6A**) after the hole is cut in the floor **102** and subfloor **104**. The size and shape of the frame **300a** will vary depending on the size of the vent cover **106** and flooring style. The frame **300a** in one example is formed from a relatively thick steel plate, e.g., a 0.25-inch steel plate, however any material durable enough to maintain a rigid template for cutting the floor **102** may be employed.

In one example the template **300a** may be secured to the flooring **102** using offset tabs **302**. The tabs **302**, as illustrated in FIG. **6A**, may be offset toward one side of the frame **300a**, although it is not required, so that the template may be flipped **180** degrees after a partial cutting of the floor **102** and/or subfloor **104** to allow for the remaining portion of the floor **102** and/or subfloor **104** initially covered by the tabs to be cut away. For example, the frame **300a** may be secured to the floor **102**, and the floor **102** and subfloor **104** cut around the inside perimeter of the frame **300a** (using, merely as examples, a saw, grinder, or the like) excepting the areas of the floor **102** covered by the tabs **302**. The frame **300a** may then be removed, and the remaining material of the floor **102** disposed underneath the tabs **302** during initial cutting removed (without the assistance of the frame **300a**). In another example approach, after initially attaching the frame **300a**, cuts in the floor **102** and/or subfloor **104** can be made along the sides of the frame **300a** adjacent the tabs **302**. Then the frame **300a** can be removed, flipped, and reattached to the floor **102** in the opposite position. When the cuts are made all the way around the remaining portion of the frame **300a**, the entire piece to be removed from the floor **102** will be free. In still another example, the frame **300a** may be secured and cuts made around the entirety of the frame **300a**. The frame **300a** may be subsequently flipped, and a fastener may be used to secure the frame **300a** to the subfloor **104**, thus firmly adhering the template over the hole. Given the depth of the subfloor **104** beneath the floor **102** with respect to the frame **300a**, a relatively longer screw may be needed in order to secure the frame **300a** to the subfloor **104**.

Once the hole in the floating floor **102** is formed, support plate **108** may be slid into position between the subfloor **104** and floating floor **102**. In the example illustrated in FIGS. **1A**, **1B**, and **2**, the support plate **108** may be inserted with the shorter dimensioned end into the hole in the floor **102**. The support plate **108** may be relatively thin and have some flexibility, as noted above, permitting the support plate **108** to be turned and wedged in between the subfloor **104** and floating floor **102**. Once the support plate **108** is positioned, the vent cover **106** may be overlaid upon the support plate **108**.

Turning now to FIG. **6B**, frame **300b** may be used in similar fashion to form a hole in fixed floor **202** as frame **300a** is described above with respect to floating floor **102**. As shown in FIG. **6B**, frame **300b** may be used to form a hole in the floor **202** corresponding to the duct opening **110**. The frame **300b** generally defines an interior dimension corresponding to the hole being formed in the fixed floor **202**. Additionally, the frame **300b** may be secured to the floor **202**, e.g., by way of mechanical fasteners such as self-tapping screws **304** which are received in tabs **302**. It

should be noted that the frame **300b** is used in generally identical fashion on the fixed floor **202** as frame **300a** is used on floating floor **102**, apart from dimensional differences resulting from the differences outlined above regarding floating floor **102** and fixed floor **202** applications. For example, in the examples illustrated above for a fixed floor **202** in FIGS. **4** and **5**, the subfloor **104** may be exposed around the perimeter of the duct **110** in order to support the outer frame **208a** and allow securing the outer frame **208a** to the subfloor **104**. Accordingly, the floor **202** and subfloor **104** may be cut in separate stages, or using different templates or frames.

Turning now to FIG. **7**, example methods associated with vent cover assemblies **100a**, **100b**, e.g., for installing vent cover assemblies **100a**, **100b**, are discussed in further detail. Process **700** may begin at block **705**, where a vent aperture or hole is formed in a floor. For example, as discussed above, where a hole in existing flooring is being cut to allow installation of the vent cover assembly, a frame or template, e.g., frame **300a** or **300b**, may be affixed temporarily to the floor to guide the cutting/grinding process. Process **700** may then proceed to block **710**.

At block **710**, a support plate may be positioned adjacent a vent aperture defined by a flooring. For example, as described above, support plate **108** or outer frame **208a** and support plate **208b**, may be positioned atop a duct opening **110**. As noted above, the support plates **108**, **208b** define a plurality of first airflow apertures **114** configured to permit airflow from a duct through the support plate **108**, **208b**. Moreover, support plates **108**, **208b** may be installed in any manner convenient. For example, in a floating floor application, e.g., such as floor **102**, support plate **108** may be slid in between subfloor **104** and floor **102**. Alternatively, in a fixed floor application, outer frame **208a** may be secured to a portion of the subfloor **104**, with the support plate **208b** supported upon the subfloor **104** by way of tabs **230** of the support plate **208b**, as described above.

Proceeding to block **715**, the support plate may be overlaid with a flush mount vent cover having an upper surface configured to extend substantially continuous with an adjacent floor surface when installed overlying the support plate. For example, as described above, a vent cover **106**, **206** may be overlaid upon a support plate **108**, or outer frame **208a** and support plate **208b**, respectively. Moreover, the vent covers **106**, **206** each define an upper surface extending parallel to, and substantially continuous with, that of surrounding floor **102**, **202**, as noted above. The vent cover **106**, **206** may define a second plurality of airflow apertures **116**. Moreover, the vent cover apertures **116** may be positioned in the vent cover **106**, **206** such that the second plurality of airflow apertures are aligned with the first airflow apertures **114** of the support plate **108**, **208b** when the vent cover is in a first installed position overlying the support plate, and the vent cover obstructs the first airflow apertures **114** when the vent cover is in a second installed position overlying the support plate.

As also discussed above, in some example approaches, the vent cover **106**, **206** may be formed of a same material as a surrounding flooring **102**, **202** defining at least in part the vent aperture or duct opening **110**. Additionally, in some examples the second plurality of airflow apertures **116** may be positioned asymmetrically with respect to a vent cover outermost perimeter or outer symmetrical shape defined by the vent cover **106**, **206**. The vent cover **106**, **206** may be configured to be placed into a second installed position from the first installed position by removing, rotating the vent

cover **180** degrees, and replacing the vent cover **106**, **206** upon the support plate **108**, **208b**. Process **700** may then proceed to block **720**.

At block **720**, process **700** may query whether vent cover assembly is being installed into a floating floor or non-floating floor application. Where a floating floor, e.g., floor **102**, is being employed, process **700** may proceed to block **725**. Alternatively, if a fixed floor application is used, e.g., floor **202**, process **700** may proceed to block **730**.

At block **725**, in a floating floor application the support plate **108** may define a support plate outermost perimeter **112** configured to be installed against or adjacent an underside of the floating floor **102** defining the adjacent floor surface **102'**. Moreover, in such applications the vent cover **106** may define a vent cover outermost perimeter **118** disposed within, or otherwise smaller than, the support plate outer perimeter **112**.

At block **730**, if a vent cover assembly is being installed into a fixed floor application, at least a portion of the support plate may be surrounded with a support plate frame, e.g., outer frame **208a**. As noted above, in fixed floor applications a support plate **208b** may be held in position by way of an outer frame **208a** that is secured to the subfloor **104**. Moreover, the support plate **208b** may be selectively removable from the outer frame **208a** while the support plate frame **208a** is secured to the subfloor, at least in a semi-permanent manner. For example, as described above an outer frame **208a** may be secured to subfloor **104** by screws or other fasteners, thereby allowing the outer frame **208a** to maintain a position upon the subfloor **104** with respect to the fixed floor **202**.

Reference in the specification to “one example,” “an example,” “one embodiment,” or “an embodiment” means that a particular feature, structure, or characteristic described in connection with the example is included in at least one example. The phrase “in one example” in various places in the specification does not necessarily refer to the same example each time it appears.

With regard to the processes, systems, methods, heuristics, etc. described herein, it should be understood that, although the steps of such processes, etc. have been described as occurring according to a certain ordered sequence, such processes could be practiced with the described steps performed in an order other than the order described herein. It further should be understood that certain steps could be performed simultaneously, that other steps could be added, or that certain steps described herein could be omitted. In other words, the descriptions of processes herein are provided for the purpose of illustrating certain embodiments, and should in no way be construed so as to limit the claimed invention.

Accordingly, it is to be understood that the above description is intended to be illustrative and not restrictive. Many embodiments and applications other than the examples provided would be upon reading the above description. The scope of the invention should be determined, not with reference to the above description, but should instead be determined with reference to the appended claims, along with the full scope of equivalents to which such claims are entitled. It is anticipated and intended that future developments will occur in the arts discussed herein, and that the disclosed systems and methods will be incorporated into such future embodiments. In sum, it should be understood that the invention is capable of modification and variation and is limited only by the following claims.

All terms used in the claims are intended to be given their broadest reasonable constructions and their ordinary mean-

## 11

ings as understood by those skilled in the art unless an explicit indication to the contrary is made herein. In particular, use of the singular articles such as “a,” “the,” “said,” etc. should be read to recite one or more of the indicated elements unless a claim recites an explicit limitation to the contrary.

What is claimed is:

1. A floor vent cover assembly, comprising:  
a flush mount vent cover; and  
a support plate configured to be secured over a duct such that an outer perimeter of the support plate is positioned underlying an adjacent floor surface of the floor vent cover assembly and such that the support plate does not rotate or translate while the flush mount vent cover is overlying the support plate, the support plate defining a plurality of first airflow apertures configured to permit airflow from the duct through the support plate;  
the flush mount vent cover having an upper surface configured to extend substantially continuous with the adjacent floor surface when installed overlying the support plate such that the upper surface of the flush mount vent cover is in contact with and parallel to the adjacent floor surface along multiple sides of the vent cover, thereby preventing rotation and translation of the flush mount vent cover relative to the adjacent floor surface while the vent cover is installed overlying the support plate, the vent cover defining a second plurality of airflow apertures, the second plurality of airflow apertures positioned in the vent cover such that the second plurality of airflow apertures are aligned with the first airflow apertures when the vent cover is in a first installed position overlying the support plate, and the vent cover obstructs the first airflow apertures when the vent cover is in a second installed position overlying the support plate.
2. The floor vent cover assembly of claim 1, wherein the second plurality of airflow apertures are positioned asymmetrically in the vent cover where the second plurality of airflow apertures meet the first plurality of airflow apertures when the vent cover is overlying the support plate, the asymmetric position of the second plurality of airflow apertures being with respect to a vent cover outermost perimeter defined by the vent cover.
3. The floor vent cover assembly of claim 1, wherein the vent cover is configured to be placed into the second installed position from the first installed position by rotating the vent cover 180 degrees.
4. The floor vent cover assembly of claim 1, further comprising a flooring defining the adjacent floor surface.
5. The floor vent cover assembly of claim 4, wherein the vent cover upper surface and adjacent floor surface are each formed of a same material.
6. The floor vent cover assembly of claim 1, wherein the vent cover includes a magnetic backing, and the support plate is formed of a magnetically susceptible material.
7. The floor vent cover assembly of claim 1, wherein the vent cover is placed into direct contact with the support plate in the first and second installed positions.
8. The floor vent cover assembly of claim 1, wherein the outer perimeter of the support plate is a support plate outermost perimeter configured to be installed to an underside of a floating floor defining the adjacent floor surface, and the vent cover defines a vent cover outermost perimeter disposed within the support plate outer perimeter.
9. The floor vent cover assembly of claim 1, wherein the second plurality of airflow apertures are positioned asymmetrically in the vent cover where the second plurality of

## 12

airflow apertures meet the first plurality of airflow apertures when the vent cover is overlying the support plate, the asymmetric position of the second plurality of airflow apertures being with respect to a vent cover outermost perimeter defined by the vent cover; and

wherein the vent cover is configured to be placed into the second installed position from the first installed position by rotating the vent cover 180 degrees.

10. The floor vent cover assembly of claim 1, wherein the vent cover is configured to be placed into the second installed position from the first installed position by rotating the vent cover.

11. The floor vent cover assembly of claim 1, wherein the support plate is in a same stationary position over the duct when the vent cover is in the first installed position and when the vent cover is in the second installed position.

12. A method of installing a floor vent cover assembly having a support plate and a flush mount vent cover, the method comprising:

positioning the support plate adjacent a vent aperture defined by a flooring, the support plate having an outer perimeter positioned underneath a surrounding adjacent floor surface defined by the flooring such that the support plate does not rotate or translate while the flush mount vent cover is overlying the support plate, the support plate defining a plurality of first airflow apertures configured to permit airflow from a duct through the support plate; and

overlying the support plate with the flush mount vent cover, the flush mount vent cover having an upper surface configured to extend substantially continuous with the adjacent floor surface when installed overlying the support plate such that the upper surface of the flush mount vent cover is in contact with and parallel to the adjacent floor surface along multiple sides of the vent cover, thereby preventing rotation and translation of the flush mount vent cover relative to the adjacent floor surface while the vent cover is installed overlying the support plate, the vent cover defining a second plurality of airflow apertures, the second plurality of airflow apertures positioned in the vent cover such that the second plurality of airflow apertures are aligned with the first airflow apertures when the vent cover is in a first installed position overlying the support plate, and the vent cover obstructs the first airflow apertures when the vent cover is in a second installed position overlying the support plate.

13. The method of claim 12, wherein the second plurality of airflow apertures are positioned asymmetrically in the vent cover where the second plurality of airflow apertures meet the first plurality of airflow apertures when the vent cover is overlying the support plate, the asymmetric position of the second plurality of airflow apertures being with respect to a vent cover outermost perimeter defined by the vent cover, and wherein the vent cover is configured to be placed into the second installed position from the first installed position by rotating the vent cover 180 degrees.

14. The method of claim 12, wherein the outer perimeter of the support plate is a support plate outermost perimeter configured to be installed to an underside of a floating floor defining the adjacent floor surface, and the vent cover defines a vent cover outermost perimeter disposed within the support plate outer perimeter.

15. The method of claim 12, further comprising establishing the vent cover being formed of a same material as a surrounding flooring defining at least in part the vent aperture.

13

16. The method of claim 15, further comprising forming the vent aperture in the flooring.

17. The method of claim 12, further comprising aligning the upper surface of the vent cover such that the upper surface extends substantially continuous with the adjacent floor surface when installed overlying the support plate.

18. A vent cover assembly, comprising:  
a flush mount vent cover; and

a support plate configured to be positioned over a duct and having an outer perimeter configured to be positioned underneath a surrounding adjacent surface such that the support plate does not rotate or translate while the flush mount vent cover is overlying the support plate, the surrounding adjacent surface being adjacent of the vent cover assembly, the support plate defining a plurality of first airflow apertures configured to permit airflow from the duct through the support plate; and

the flush mount vent cover having an upper surface configured to extend substantially continuous with the adjacent surface when installed overlying the support plate such that the upper surface of the flush mount vent cover is in contact with and parallel to the adjacent surface along multiple sides of the vent cover, thereby preventing rotation and translation of the flush mount vent cover relative to the adjacent surface while the vent cover is installed overlying the support plate, the vent cover defining a second plurality of airflow apertures, wherein the second plurality of airflow apertures are aligned with the first airflow apertures in a first relative position when the vent cover is overlying the support plate such that airflow is permitted through the support plate and the vent cover via the first and second airflow apertures, and wherein the second plurality of airflow apertures are shifted with respect to the first airflow apertures and the vent cover at least partially obstructs the first airflow apertures in a second relative position when the vent cover is overlying the support plate, such that airflow through the support plate and vent cover via the first and second airflow apertures is relatively restricted.

19. The vent cover assembly of claim 18, wherein the second plurality of airflow apertures are shifted from the first relative position to the second relative position by rotating the vent cover.

14

20. The vent cover assembly of claim 18, wherein the support plate is in a same stationary position over the duct when the second plurality of airflow apertures of the vent cover are in the first relative position and when the second plurality of airflow apertures of the vent cover are in the second relative position.

21. The vent cover assembly of claim 18, wherein the second plurality of apertures in the flush mount vent cover are shifted with respect to the adjacent floor surface when the second plurality of airflow apertures of the vent cover are shifted with respect to the first plurality of airflow apertures from the first relative position to the second relative position.

22. The vent cover assembly of claim 18, wherein the first plurality of airflow apertures are entirely obstructed by the vent cover when the second plurality of airflow apertures of the vent cover are in the second relative position.

23. The vent cover assembly of claim 18, wherein the first plurality of airflow apertures are aligned with the second plurality of airflow apertures when the second plurality of airflow apertures of the vent cover are in the first relative position such that airflow through the first plurality of airflow apertures is freely permitted.

24. The vent cover assembly of claim 18, wherein the support plate is configured to be secured in a stationary position over the duct, the outer perimeter of the support plate is a support plate outermost perimeter; and

wherein the second plurality of airflow apertures are positioned asymmetrically in the vent cover where the second plurality of airflow apertures meet the first plurality of airflow apertures when the vent cover is overlying the support plate, the asymmetric position of the second plurality of airflow apertures being with respect to a vent cover outermost perimeter defined by the vent cover, and the vent cover is configured to be placed into the second relative position from the first relative position by rotating the vent cover 180 degrees.

25. The vent cover assembly of claim 18, wherein the upper surface of the flush mount vent cover is in contact with and parallel to the adjacent floor surface about an entire perimeter of the vent cover.

26. The vent cover assembly of claim 18, wherein the vent cover assembly is a floor vent cover assembly, and the adjacent surface of the vent cover assembly is a floor surface.

\* \* \* \* \*